

# REMOTE DISPLAYS

Clear and Bright  
For Optimal  
Distance Viewing

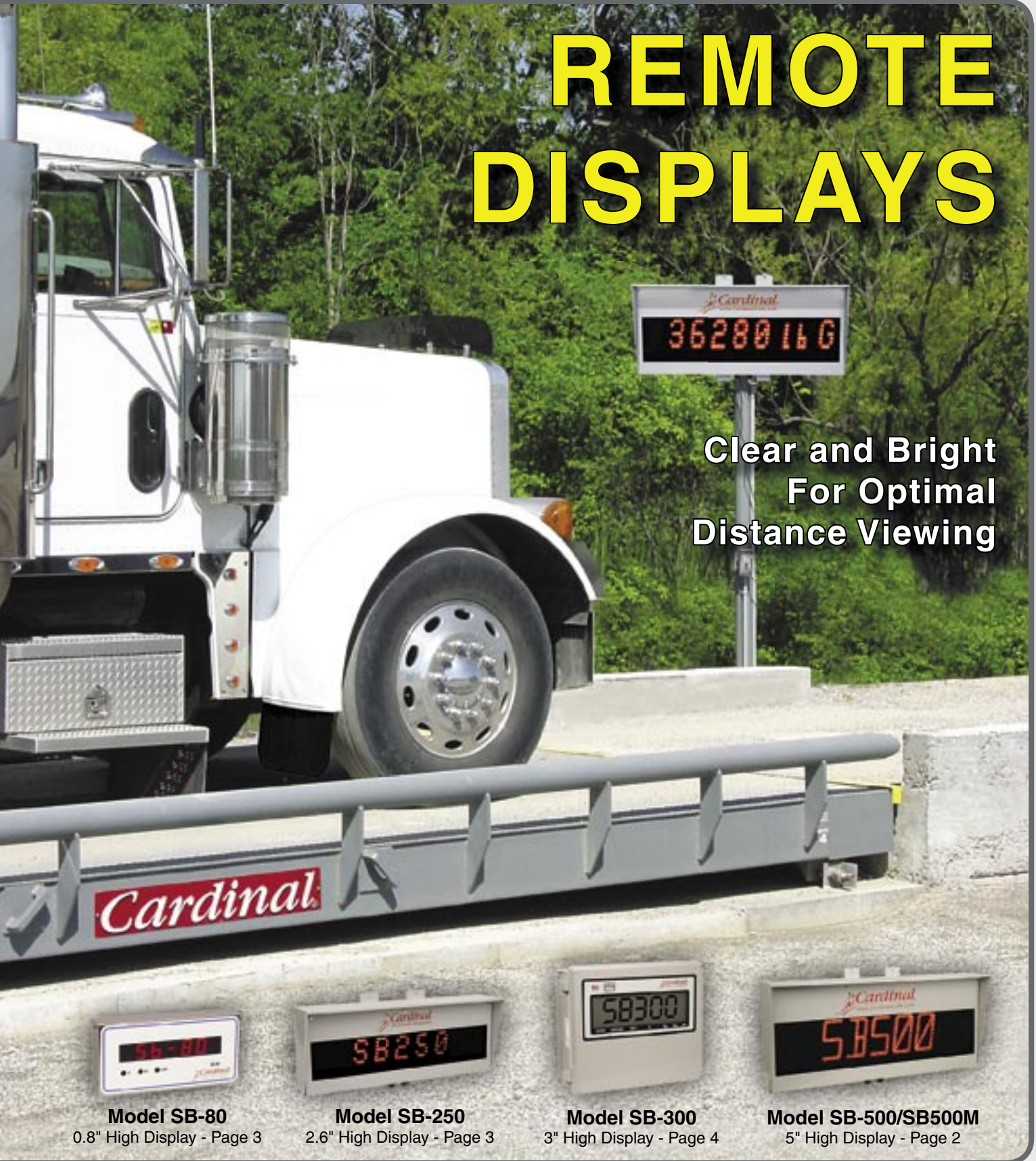

**Model SB-80**  
0.8" High Display - Page 3

**Model SB-250**  
2.6" High Display - Page 3

**Model SB-300**  
3" High Display - Page 4

**Model SB-500/SB500M**  
5" High Display - Page 2

# SB-500 Remote Display

Serial, Fiber Optic or Ethernet Connectivity

- 5" (127 mm) high intensity LED display
- 10 levels of brightness
- Message board standard with SB-500M
- Cardinal's own *Smart Configuration* software allows custom formats

- Autolearn mode allowing plug-and-play with virtually any digital indicator
- NEMA 4/IP65 weatherproof enclosure
- Built-in rain hood
- Mounting tabs for easy installation

Cardinal's giant SB-500 and SB-500M remote displays are clearly visible for highway applications and flexible enough for use indoors or out. Their 5" (127 mm) high-intensity LED displays are viewable in direct sunlight with a viewing angle of 140°. These units feature ten levels of display intensity which adjust automatically via an ambient

light sensor, ensuring readability both day and night. The painted mild steel, weatherproof enclosures meet NEMA 4/IP65 requirements and incorporate tabs for mounting on a vertical surface. The built-in rain hoods provide extra protection and greater visibility during inclement weather. Daisy chain multiple units together for increased visibility.

## SB-500

The SB-500 utilizes Cardinal's autolearn mode allowing the remote display to plug and play with virtually any digital indicator via standard RS-232 connection, 20mA, RS422/485. Alpha display of units makes the SB-500 easy to read, without confusing status lamps.



## SB-500M

The SB-500M employs **message board capabilities** for directing vehicles on and off the scale or simply displaying scrolling messages. With custom configuration, the SB-500M can display moving and static alpha characters, and each digit consists of up to 24 segments for greater readability.



## SB-500S

Choose Cardinal's SB-500S, with **stainless steel enclosure**, for corrosion-free protection that stands up to rugged use in harsh environments.



Cardinal's proprietary *Smart Configuration* software allows a custom configuration through the upload of serial data. Custom design the SB-500M and SB-250 to display messages directly from a programmable indicator or PC.

<b>Character Height</b> .....	5" / 127 mm
<b>Character Type</b>	
SB-500 and SB500S.....	7-segment, 6-digit with decimal points and three 24-segment alpha characters
SB-500M.....	Nine 24-segment alpha characters
<b>Annunciators</b> .....	lb, kg, T, t, G, N (if output from indicator)
<b>Ambient Light Levels</b> .....	total darkness to direct sun
<b>Power Input</b> .....	115/230 VAC 50/60 Hz
<b>Power Consumption</b> .....	60 watts, maximum
<b>Interface</b> .....	20mA - active or passive, RS-232, RS-422, RS-485 fiber optic, ethernet
<b>Display Capacity</b> .....	-99999 to 999999
<b>Enclosure Rating</b> .....	NEMA 4/IP65
<b>Enclosure</b>	
SB-500 and SB500M.....	painted mild steel
SB-500S.....	stainless steel
<b>Viewing Angle</b> .....	+/- 70°
<b>Viewing Range</b> .....	250' / 76 m
<b>Ambient Temperature</b> .....	-15° to +130° F (-26° to 54° C)
<b>Ambient Humidity</b> .....	5 to 100%
<b>Character Format</b> .....	all standard printable ASCII characters

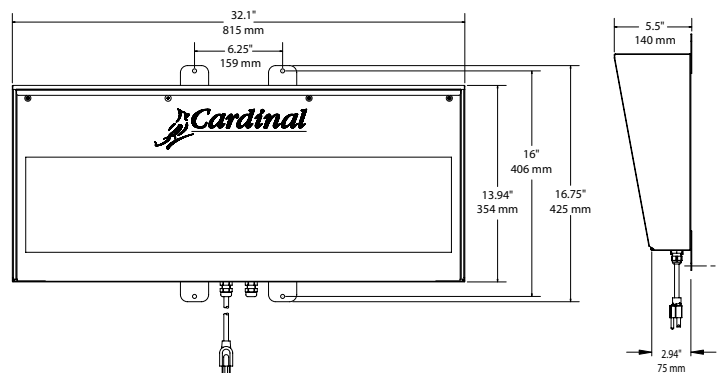



# SB-250 Remote Display

The SB-250 employs many of the same features of the SB-500, but in a smaller package. Message board capabilities are standard with all

SB-250s and feature digits 2.6 inches high consisting of an array of nine 5 x 7 alphanumeric characters for crisp, clean readouts of upper and lower case letter messages.

**SPECIFICATIONS**



**Character Height**.....2.6" / 66 mm  
**Character Type**.....5 x 7 with descenders and decimal points  
**Annunciators**.....lb, kg, T, t, G, N (if output from indicator)  
**Ambient Light Levels**.... total darkness to direct sun  
**Power Input**.....115/230 VAC 50/60 Hz  
**Power Consumption**.....60 watts, maximum  
**Interface**.....20mA - active or passive, RS-232, RS-422, RS-485 fiber optic, ethernet  
**Display Capacity**.....-99999 to 999999  
**Enclosure Rating**.....NEMA 4/IP65  
**Enclosure**.....painted mild steel  
**Viewing Angle**.....+/- 70°  
**Viewing Range**.....200' / 61 m  
**Ambient Temperature**.....-15° to +130° F (-26° to 54° C)  
**Character Format**.....all standard printable ASCII characters

- 2.6" (66 mm) high intensity LED display
- 10 levels of brightness
- Message board standard
- Cardinal's own *Smart Configuration* software allows custom formats
- Connect via serial, fiber optic, or ethernet to your digital indicator

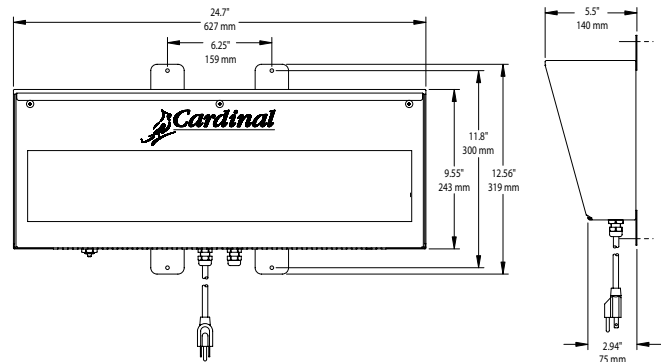

# SB-80 Remote Display

Cardinal's SB-80 features a 0.8" high LED display, viewing range of 20 feet, AC adapter (included), and combination of desk and wall-mount stainless steel enclosure. For indoor use only, this unit is perfect for warehouse floor scales. It requires a two-wire connection to the indicator, with a maximum distance of 25 feet from the indicator for RS232 and 1,000 feet for a 20mA current loop.

- 6-digit, 0.8" high LED display
- Displays remote readout and tracks digital weight indicator
- Viewing range of 20 feet / 6 meters
- Combination desk and wall-mount stainless steel enclosure

**SPECIFICATIONS**

**Display**.....0.8" / 20 mm high LED, 7 digits (6 for weight, 1 for minus sign)  
**Power**.....12 VDC, 300mA adapter (115 VAC, 60 Hz adapter)  
**Annunciators**.....lb, kg, ZERO  
**Interface**.....20mA current loop, RS-232  
**Display Capacity**.....-999999 to 999999  
**Enclosure**.....stainless steel  
**Viewing Range**.....20' / 6 m

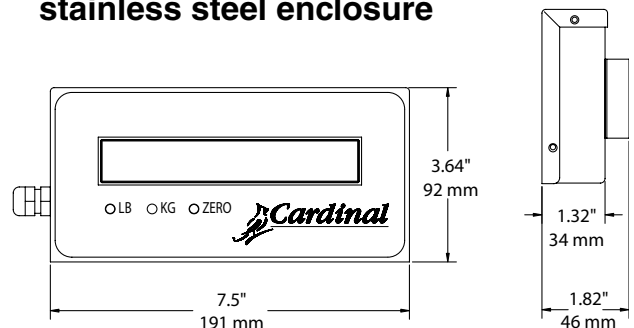



# SB-300 Remote Display

- **3" (76 mm) high numerals**
- **Transflective LCD display**
- **Automatic backlighting**
- **Tough fiberglass NEMA 4 enclosure**
- **Highly visible in ALL lighting**
- **Daisy chain multiple units to one indicator**



Durable, weatherproof fiberglass prohibits corrosion in abusive environments.

3" high transflective display can be seen day or night... even at a distance!



Automatic backlighting activates LCD lamps only when needed.

Cardinal Scale reserves the right to improve, enhance or modify features and specifications without prior notice.

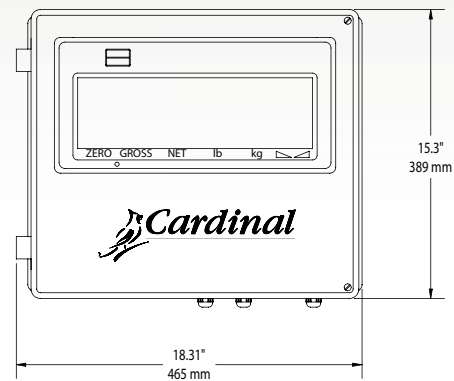
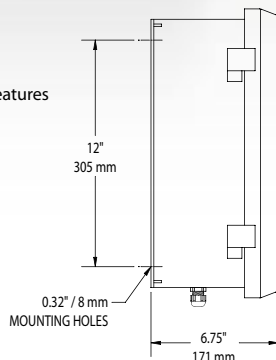
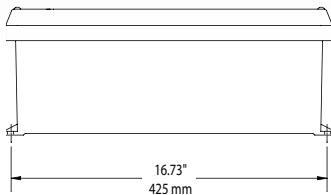

<b>Character Height</b> .....	3" / 76 mm
<b>Character Type</b> .....	6-digit, 7-segment
<b>Display</b> .....	transflective LCD with light sensitive backlighting
<b>Display Capacity</b> .....	-99999 to 999999
<b>Backlight Type</b> .....	Photo detector controlled CCFL, 10,000 Hr Life
<b>Annunciators</b> .....	6 (Zero, Gross, Net, lb, kg and Motion)
<b>Ambient Light Levels</b> .....	total darkness to direct sun
<b>Power Input</b> .....	3 wire, 95 to 264 VAC, 60 Hz
<b>Interface</b> .....	20mA current loop, RS-232 (10' / 3 m cable furnished)
<b>Enclosure Rating</b> .....	NEMA 4/IP65
<b>Enclosure</b> .....	fiberglass
<b>Viewing Range</b> .....	up to 100 feet / 30 m
<b>Ambient Temperature</b> .....	-10° F to +120° F -23° C to 49° C

**Cardinal**  
 Cardinal Scale Manufacturing Co.  
 203 E. Daugherty, Webb City, MO 64870 USA  
 Ph: 417-673-4631 or 800-441-4237 • Fax: 417-673-5001  
[www.cardinalscales.com](http://www.cardinalscales.com)

**Sold By:**

